



Very early fire detection with
aspirating smoke detectors.

SecuriSmoke ASD

Two product families for every application



Data centres

Without a doubt: many companies would come to a standstill without a functioning ICT infrastructure. Server rooms in SMEs, mobile telephony base stations and large data centres play a key role. Protecting them from fires is a complex task, as high and turbulent air currents make it difficult to detect diluted, early-stage smoke. With their multiple alarm levels, SecuriSmoke ASD aspirating smoke detectors support appropriate interventions and trigger extinguishing systems automatically.



Logistics and warehouses

Modern, automated and large-scale storage facilities are key infrastructure in the supply chain of almost every company. And they are sensitive: even a small fire can seriously jeopardise business continuity. Aspirating smoke detection technology ensures optimum protection. Aspirating smoke detectors from Securiton react quickly and precisely in the event of a fire; their early warning capability allows it to be brought under control before it takes hold.



Clean rooms and controlled environments

Controlled environments require highly reliable fire protection. At the same time, they pose specific challenges when it comes to fire alarm system design and maintenance – for example, in environment-controlled production situations, in sterile zones in hospitals, and in large semiconductor manufacturing facilities. The detection units of the SecuriSmoke ASD aspirating smoke detectors are located in easily accessible locations to simplify their maintenance. Their problem-free operation minimises the risks to people and materials, thus ensuring business continuity.



Difficult environments

Large numbers of warehouses are being built to meet the increasing demands of population growth, changing consumer behaviour and innovative goods. Rapidly growing e-commerce through digitisation requires dedicated warehouses, such as cold stores, to meet the growing demand for fresh, frozen and perishable goods. SecuriSmoke ASD aspirating smoke detectors can be used in the immediate vicinity of stored goods in spite of cold or draughts. Early fire detection ensures continuity of business.



Rail and rapid transit hubs

Rail hubs, including suburban rail and metro systems, are important elements of public transport. As they largely operate underground, the evacuation of trains and stations takes longer in the event of a fire. Every second counts for emergency services evacuating passengers at risk – early notification of a potential fire is crucial. This is where SecuriSmoke ASD aspirating smoke detectors come into their own, thanks to multiple alarm levels and fast responses.



Large open spaces

Large open spaces such as theatres, atriums and airport terminals pose a wide range of challenges in terms of fire protection. Point-type smoke detectors are often ineffective due to smoke dilution and stratification. Here SecuriSmoke ASD aspirating smoke detectors perform their job reliably: these early warning devices benefit from multiple alarm levels, enabling staggered responses according to the situation for the preservation of life and property.

SecuriSmoke ASD 2000 product range: The start of a new era of fire protection

With more than half a century of unrivalled expertise, Securiton is a global specialist and trusted partner for the most demanding fire protection solutions using aspirating smoke detectors (ASDs). With the SecuriSmoke ASD 2000 product range, we are entering the next chapter in our ASD history – in keeping with the motto “to be continued”.

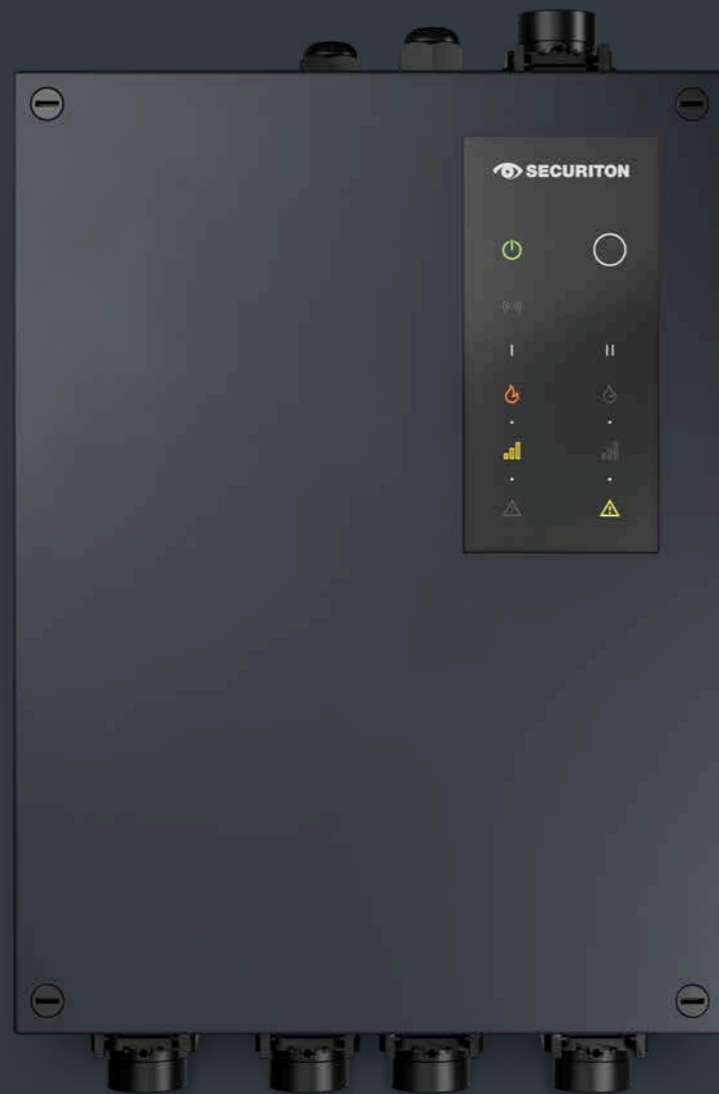

SecuriSmoke ASD 2000 – our experience, your security

The SecuriSmoke ASD 2000 product range impresses with its simple and efficient work steps – virtually tool-free – ranging from planning, installation and commissioning to document maintenance. Supported by the latest software tools, operation is simple and intuitive even for occasional users. A device with four sampling channels covers many country-specific guidelines and project-specific requirements in the best possible way. Separate airflow monitoring enables precise localisation and identification of deviations per channel.



Newest generation of highly sensitive smoke sensors

Our SecuriSmoke ASD 2000 product range is equipped with the newest generation of highly sensitive smoke sensors able to detect even the tiniest smoke particles with their ultra-low alarm threshold of 0.01%/m and a maximum sensitivity of 0.001%/m. This ensures the earliest possible detection, enabling rapid step-by-step intervention and minimising the risk of fire damage.



Simply intuitive – ASD planning with SecuriSmoke PipeFlow 3D

The high-quality 3D planning tool SecuriSmoke PipeFlow 3D makes planning ASD projects easier thanks to simple import of floor plans as a basis for the project as well as the ability to view them in all dimensions and levels of detail. Intuitive user interfaces eliminate the need for lengthy training sessions and enhance both productivity and efficiency.

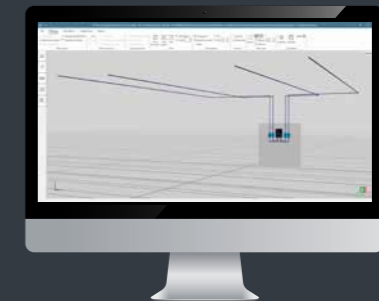

From commissioning to support: easy handling with the SecuriSmoke MobileConfig app

Thanks to intensive user tests, the SecuriSmoke MobileConfig app has been designed to be extremely intuitive and user-friendly. This ensures that even occasional users can find their way around with ease, thus minimising training and boosting productivity. Simple and automated data import and export further increase efficiency and minimise the error rate.



Simply outstanding, powerful and robust

SecuriSmoke ASD 2000 is founded on more than 50 years of experience and expertise in early fire detection using aspirating smoke detectors. The new product range is equipped with numerous innovative features and functions and sets new technological standards.



SecuriSmoke ASD 2001,
1 channel



SecuriSmoke ASD 2002,
2 channels



SecuriSmoke ASD 2004,
4 channels

Designed for use in the most demanding environments

Even under the most challenging and demanding ambient conditions, the new ASD generation guarantees the most reliable and efficient early fire detection. At the same time, it is the quietest device on the market, even without external silencers, making it particularly suitable for sensitive environments such as hospitals, museums or historic buildings.

- IP 54 protection class: Optimal internal device protection against dust and splash water
- Universal uses and applications: High-bay storage, large data centres, historic buildings, large/high halls, etc.
- International approvals/certificates: VdS, UL*, FM*, ActivFire*, CCCF*, EAC*
- Total length of all sampling pipes: up to max. 700 m
- Whisper-quiet: Sound pressure level 21 dB (A)
- Permissible temperature range: -30 °C* to +60 °C

*in preparation

Technological innovations for even greater reliability

Internal maintenance-free centrifugal separator filter (CS filter)* increases service life and reduces maintenance costs

The internal CS filter separates larger dust particles from smaller smoke particles so that only the smaller particles enter the measuring chamber. False alarms and the associated downtimes are reduced, the service life of the smoke sensors is increased and costs are optimised as a result.

Stable and robust airflow sensors ensure reliable Security

The innovative, ultrasonic airflow sensors guarantee reliability and stability. They are not prone to soiling and withstand temperature fluctuations. With a sensor on each channel, problems can be quickly located and verified.

External coarse/insect protection filter* minimises the risk of false alarms

The coarse/insect protection filter is mounted on the outside and designed to catch even the smallest insects. It thus offers reliable protection against false alarms. Cleaning can be done from the outside at any time without tools and without opening the device, saving time and costs.

Modular device design maximises flexibility and sustainability

Thanks to a modular design and clever click system, all device components can be cleaned, repaired and replaced easily and efficiently on site without any special tools. This reduces maintenance and repair costs and minimises downtime. The new ASD generation also sets a benchmark in terms of sustainability: the availability of numerous spare parts significantly reduces waste.

* patent pending

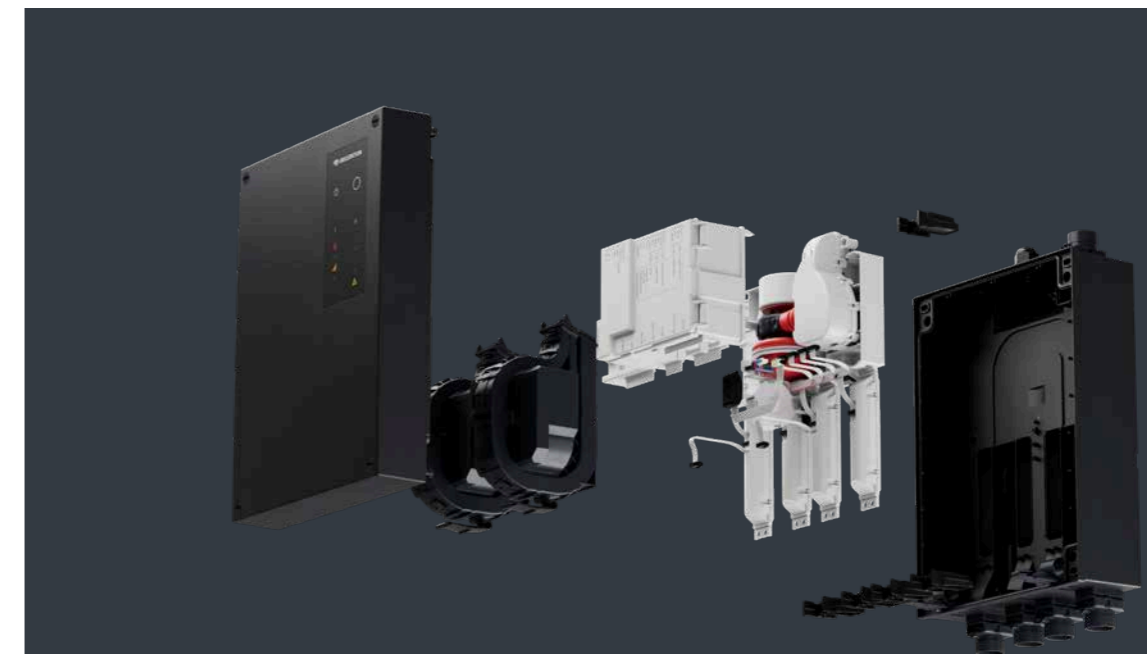

Our tried-and-tested ASD models:
as reliable as ever



ASD 535-4, 2 channels
Smoke level indicator

SecuriSmoke ASD 535 – for large monitoring areas

- Immune to environmental contaminants such as dust, dirt, moisture and steam
- Applications: high-bay storage and deep-freeze warehouses, large data centres, historic buildings, large/high halls, etc.
- Approvals/certificates: VdS, DIBt, UL, FM, ActivFire, CCCF, EAC, SIL
- Total length of all sampling pipes: 2 x 400 m
- Sound pressure level: 34 dB (A)
- Protection type: IP 54
- Permissible temperature range: -30 °C to 60 °C



ASD 535-3, 1 channel
Smoke level indicator



ASD 535 HD, 1 channel
Smoke level indicator



ASD 535 HD, 2 channels
Smoke level indicator

SecuriSmoke ASD 535 HD – for extreme environments

- Ideal for use in corrosive environments
- Applications: metal industry, woodworking industry, agriculture, etc.
- Approvals/certificates: VdS, DIBt, UL, FM, ActivFire, CCCF, EAC, SIL
- Total length of all sampling pipes: 2 x 400 m
- Sound pressure level: 34 dB (A)
- Optional surge protection
- Coated printed circuit boards
- Protection type: IP 66
- Permissible temperature range: -30 °C to +60 °C



ASD 533-1, 1 channel



ASD 533-2, 2 channels

SecuriSmoke ASD 533 – for large monitoring areas

- Applications: Lift shafts, museums, cultural artefacts, halls, cinemas, etc.
- Approvals/certificates: VdS, UL, FM, ActivFire, EAC
- Total length of all sampling pipes: 2 x 200 m
- Sound pressure level: 34 dB (A)
- Protection type: IP 54
- Permissible temperature range: -20 °C to +60 °C



SecuriSmoke ASD 532 – for medium-sized monitoring areas

- Compact design
- Applications: Prison cells, clean rooms, laboratories, server racks, telecommunications equipment, etc.
- Approvals/certificates: VdS, UL, FM, ActivFire, CCCF, EAC, SIL
- Total length of all sampling pipes: 120 m
- Sound pressure level: 25 dB (A)
- Protection type: IP 54
- Permissible temperature range: -20 °C to +60 °C



SecuriSmoke ASD 531 – for small monitoring areas

- Simple three-step configuration at the device itself (without software/PC)
- Applications: individual server racks, clean rooms, false ceilings, etc.
- Approvals/certificates: VdS, UL, FM, ActivFire, CCCF, EAC
- Total length of all sampling pipes: 75 m
- Sound pressure level: 25 dB (A)
- Protection type: IP 54
- Permissible temperature range: -10 °C to +55 °C

SecuriSmoke PipeFlow 3D: the next level of ASD planning

SecuriSmoke PipeFlow is a user-optimised, intuitive and high-quality 3D planning tool that makes ASD planning even easier and more efficient for you.

The simple import of floor plans in the most common file formats, along with the ability to view them in all dimensions, facilitates and optimises planning and communication between project participants. This allows you to identify and eliminate any discrepancies during the design process and thus before they are actually created. The ASD planning view can be rotated on both the X and Y axes and the sampling points can be easily defined at the touch of a button. All pipe materials can be exported to a material list and all views can be individually adapted for your project report. The intuitive user interfaces also increase your productivity and minimise training effort.

Your advantages

- Saves time thanks to minimum training requirements
- Saves time plus security thanks to simple import of floor plans in the most common file formats
- Optimised communication between project participants and minimisation of errors
- High productivity thanks to intuitive user interfaces
- VdS-approved software

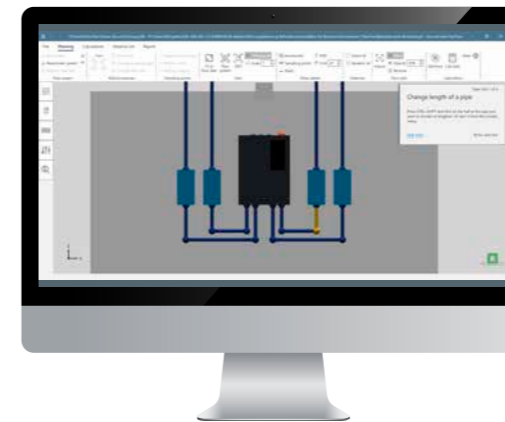

Tips and help texts further simplify operation

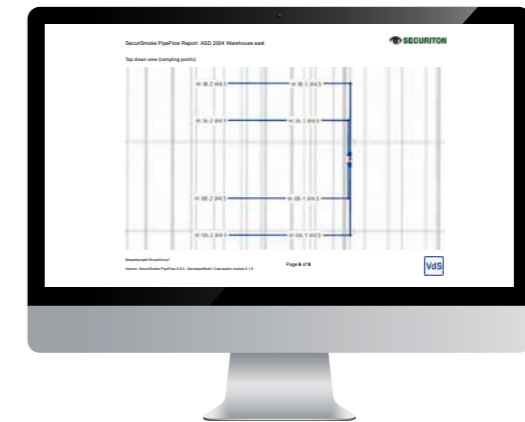

Customisable view options in the PipeFlow report

3D views based on an imported floor plan

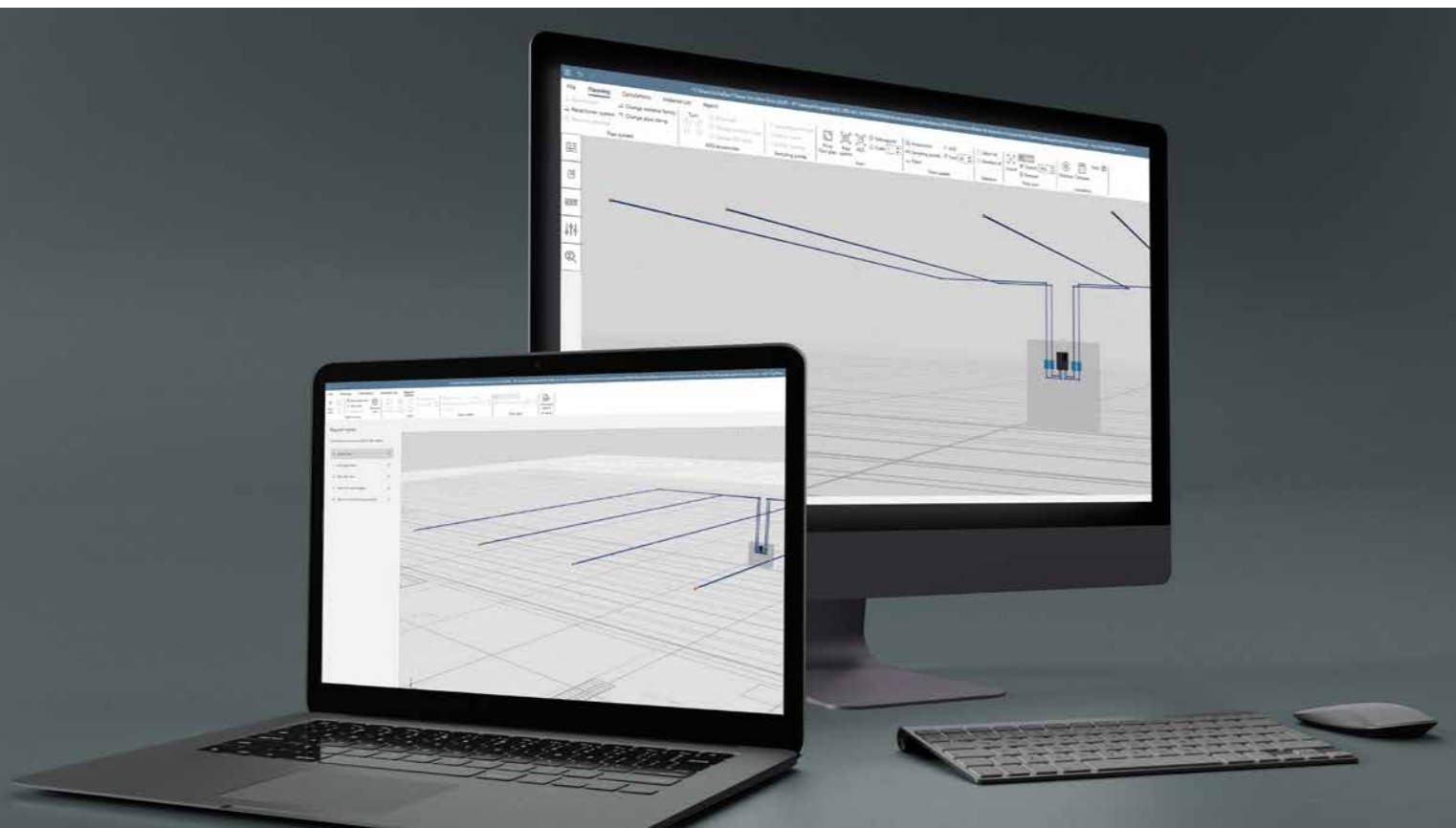

The most important functions at a glance:

- Realistic 3D views
- Import floor plans in the most common formats (e.g., .pdf, .png, .jpg, .bmp, .tif, .svg, .gif)
- Your choice of views for reports (adaptable to your processes)
- Tips and help texts
- Planning compliant with EN 54-20 (Classes A, B and C) as well as NFPA 72, 75* and 76*

*in preparation

Tried-and-tested ASD PipeFlow remains available

Our tried-and-tested ASD PipeFlow continues to guide you in simple and logical steps through your planning with **SecuriSmoke ASD models 535, 533, 532 and 531**. With its practical optimisation function, the calculation software always looks for the ideal balancing of sampling pipes so that each sampling hole has the same sensitivity. All accessories for the sampling pipe are also integrated into the VdS-approved software.



SecuriSmoke MobileConfig app: User-friendliness redefined

The SecuriSmoke MobileConfig app redefines user-friendliness. The new app is effortless to use and extremely intuitive due to optimised intensive user testing, application of user experience, and requirement engineering methods.

Simple and automated data import and export as well as targeted user guidance make handling easier and increase your efficiency. Simple maintenance work can easily be carried out by occasional users such as in-house technicians without the need for lengthy training. With the SecuriSmoke MobileConfig app, all information can be called up at any time, even when on the move, while the error rate during handling is significantly reduced thanks to managed processes. The intuitive event display and the different colours and icons give you an optimal overview. This allows you to initiate interventions quickly and efficiently if necessary. Comprehensive diagnostic and log data are also available at the touch of a button.

Your advantages

- Time savings thanks to intuitive operation and low training requirements
- Low error rate thanks to simple operation and user guidance
- High productivity thanks to intuitive user interfaces
- Availability of ASD information anywhere at any time
- Prevention of incorrect manipulations thanks to the authorisation allocation levels

Highest data security requirements

The SecuriSmoke MobileConfig app is equipped with the latest security precautions and meets Securiton's stringent quality requirements. The app uses standard, secure encryption methods and follows a multi-level authentication and authorisation concept.



The most important functions at a glance:

- Display of all aspirating smoke detectors in the vicinity (within BLE* distance)
- Guided commissioning of the aspirating smoke detector
- Controls such as event reset, isolation, time synchronisation, etc.
- Seamless documentation through advanced event memory
- Simple sharing of diagnostics and log data with 2nd level support

*BLE = Bluetooth Low Energy



Dashboard

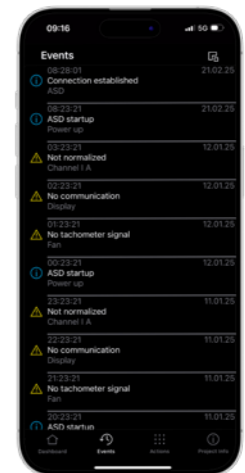

Event memory

Tried-and-tested ASD Config remains available

Our tried-and-tested ASD Config still enables you to configure your **SecuriSmoke models 535, 533, 532 and 531**, efficiently, conveniently and securely. The software's extensive analysis functions and setting options provide you with important information for safe and economical operation: This makes document maintenance easy even in hard-to-reach installation locations and eliminates operational interruptions and faults. Thanks to RS-485 networking, you can also visualise and operate all networked aspirating smoke detectors (SecuriSmoke ASD 535 and SecuriSmoke ASD 532) at the same time.

New intuitive user experience with the SecuriSmoke ASD 2000 product range

User-friendliness and efficiency were particularly important in the development of the new ASD 2000 product range. With a clear goal: to design process steps that are as simple, intuitive and efficient as possible to maximise ease of use and user satisfaction.

Your advantages in all project phases

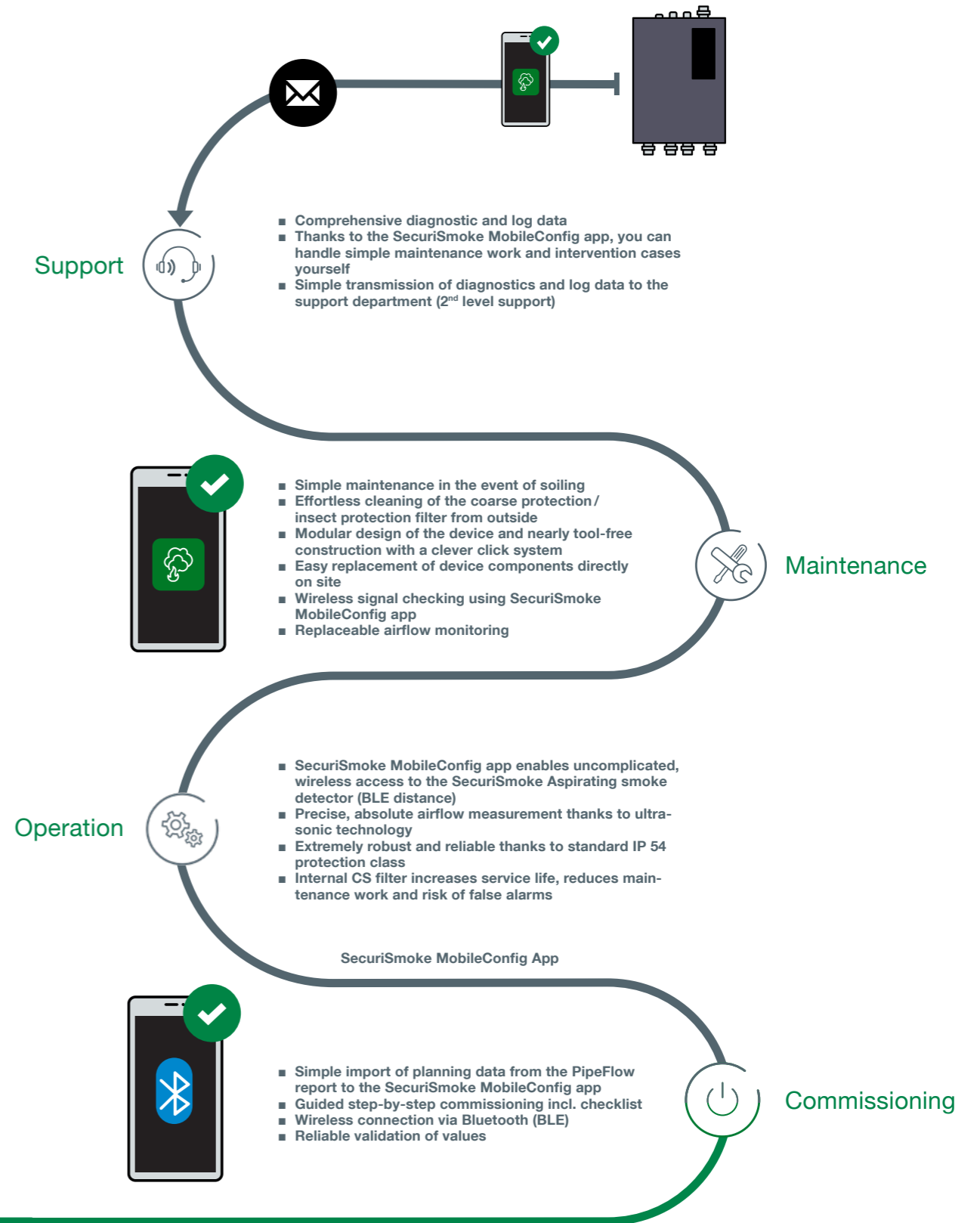
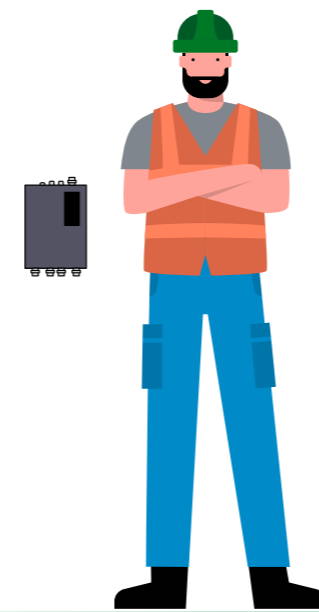
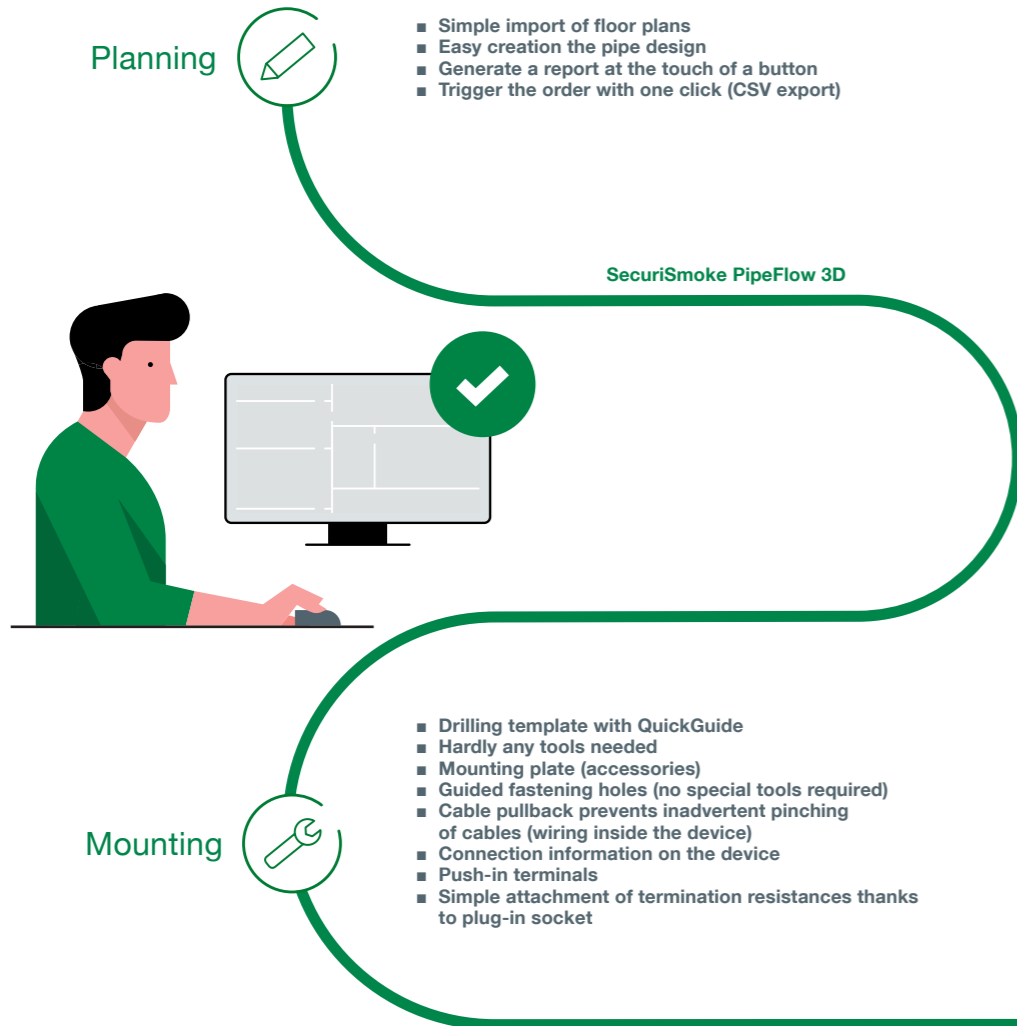

Intelligently networked

Perfect overview and easy operation with NetSoft

- The NetSoft software tool visualises live data from aspirating smoke detectors on a PC
- Live states of the aspirating smoke detectors are visible on the building plan
- Full control of networked aspirating smoke detectors
- Extensive data storage and trending function

Intelligently networked with FidesNet

- Networking of up to 100 aspirating smoke detectors with a FidesPort NCU900
- Visualisation on the FidesControl 7-inch colour touch display
- Full control of networked aspirating smoke detectors
- Simple connection to superordinate systems via Modbus and SNMP

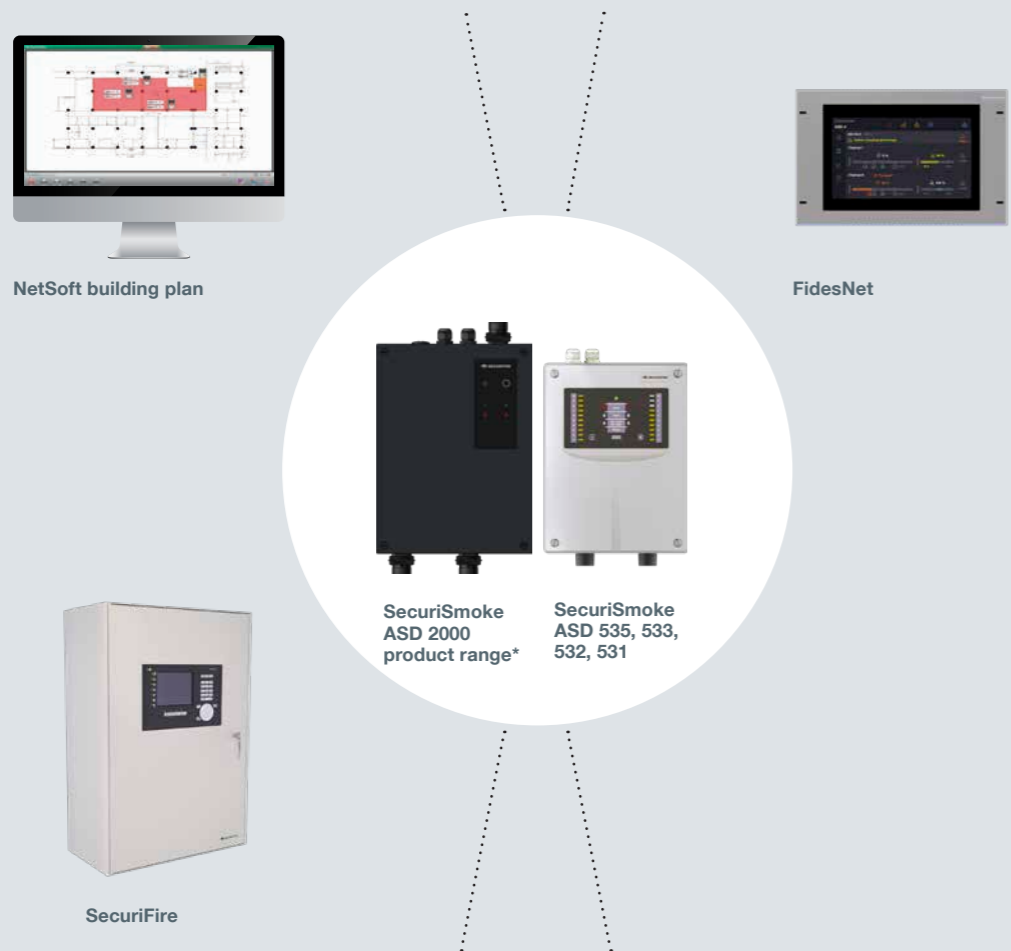

SecuriFire makes central configuration and maintenance easy

- Networking with the fire alarm control panel via an addressable loop
- Efficient commissioning and maintenance thanks to the Config Over Line function

Other networking options

- Effortless networking with fire alarm control panels from third-party providers via relay contacts

* The features shown are under development for the SecuriSmoke ASD 2000 product range and will be added to future releases. Available updates can be simply installed on the device at any time using remote access.

Key features at a glance

Type	ASD 2000	ASD 535
Number of sensors	1 / 2	1 / 2
Number of channels	1/2/4	1 / 2
Sensitivity	0,001 – 30%obs/m	0,002 – 10%obs/m
Sampling holes per ASD (Classes A/B/C)	2001: 31/80/120 2002: 62/160/240 2004: 62/160/240	535-1 and 535-3: 18/56/120 535-2 and 535-4: 35/112/240
Length of tube network Per sensor/ASD	2001: 400 m 2002: 400 m/700 m 2004: 400 m/700 m	535-1, 535-2 and 535-3: 300 m 535-4: 600 m
Distance to farthest sampling hole	1 x 150 m/2 x 130 m/4 x 90 m	110 m
Monitoring area	2001: 3,000 m ² 2002: 5,760 m ² 2004: 5,760 m ²	535-1 and 535-3: 2,880 m ² 535-2 and 535-4: 5,760 m ²
Temperature range	-30 °C* to +60 °C	-30 °C to +60 °C
Noise generation	21 dB	34 dB
Configuration	Via app/PC*	Via PC
Airflow sensors	Ultrasonic	Calorimetric
BLE	Yes	—
Ethernet	Optional*	—
RS-485	Optional*	Optional
Relays on board	3 to 5	3
IP protection class	54	54
Certifications	VdS, UL*, FM*, country approvals*	VdS, UL, FM, country approvals

*in preparation

Vertical application management: Expert knowledge in a wide range of industries and applications

Our support for your security

Our exclusive knowledge library offers design guides, case studies, white papers and much more, including interesting facts about the wide range of fire detection and fire alarm system applications in diverse industries. You also have access to design drawings, common codes and applicable standards.

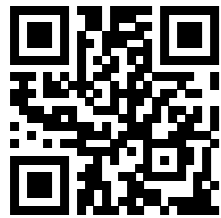

Comprehensive range of accessories for all challenges

Whether standard applications or demanding special environments, we offer the matching accessories, from tube materials to special solutions.

Applications Accessory categories.



Industrial applications



Extensive range of sampling tubes



Object surveillance



Applications in deep-freeze warehouses



Standard applications



Accessories for Ex zones

In use worldwide with international certifications

International product tests and certifications enable the SecuriSmoke ASD aspirating smoke detectors universal market access and worldwide use.

SecuriSmoke ASDs speak multiple languages: globally applicable standards such as NFPA 72, FIA Code of Practice, VDE 0833-2, TS 54-14, BS 5839-1, etc. can be met with confidence when planning a system.

Securiton maintains a global presence. Our head office is in Switzerland, with branches or local employees in Argentina, Australia, Benelux, Brazil, China, India, Indonesia, Italy, Jordan, Malaysia, Mexico, the Philippines, Saudi Arabia, Singapore, South Africa, South Korea, Spain, Thailand, the UK, the United Arab Emirates and Vietnam.



The SecuriSmoke ASD 2000 product range at a glance

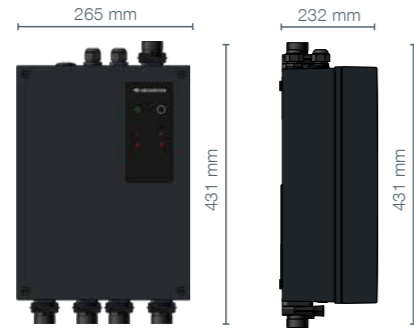

	ASD 2001	ASD 2002	ASD 2004
Product details			
Channels	1	2	4
Smoke sensor	1	2	2
Monitoring area	3,000 m ²	5,760 m ²	5,760 m ²
Smoke level indicator	Flashing frequency		
Programming/ Configuration	SecuriSmoke MobileConfig app		
Sampling pipe calculation	PipeFlow 3D (3.0)		
Applications	High-bay storage, large Data centres, historical Buildings, large/high halls, etc.		
Coated printed circuit board/ surge protection	—		
Approvals	VdS, UL*, FM*, ActivFire*, CCCF*, EAC*		

*in preparation

		ASD 2001	ASD 2002	ASD 2004
Technical data				
Supply voltage range	EN 54 FM/UL		14 to 30 VDC 16.4 to 27 VDC	
Power consumption	Type at 24 VDC	412 to 425 mA	447 to 468 mA	467 to 490 mA
Alarm sensitivity	Alarm Pre-signal		0.01 to 30%/m 0.001 to 27%/m	
Alarm levels			5 (3 pre-signals, alarm, alarm 2) Adjustable pre-signals 10 to 90%	
Number of sampling holes per channel/total	EN 54-20, Class A	31	31/62	16/62
	EN 54-20, Class B	80	80/160	40/160
	EN 54-20, Class C	120	120/240	60/240
System limits according to EN 54-20, Class C	Max. overall length of all sampling pipes			
	Per ASD	400 m	700 m	700 m
	Per detector		400 m	
Fan	Sound pressure level		21 dB (A)	
Housing	Protection type		IP 54	
Operating temperature/ humidity	Evaluation unit		-30°C* to +60°C 95% rel. hum.	
Relays	Number	3 (1× fault, 1× alarm, 1× pre-signal)	5 (1× fault, 1× alarm per detector, 1× pre-signal)	5 (1× fault, 1× alarm per detector, 1× pre-signal)
	Contact load		50 VDC/1 A (UL 30 VDC)	
Interfaces	Operating app		BLE	
	Inputs		Reset, authorisation	
SecuriFire integration			By means of relay connection	
Event memory/ analogue values	On board		20,000 events	

*in preparation

The tried-and-tested SecuriSmoke ASD product ranges at a glance

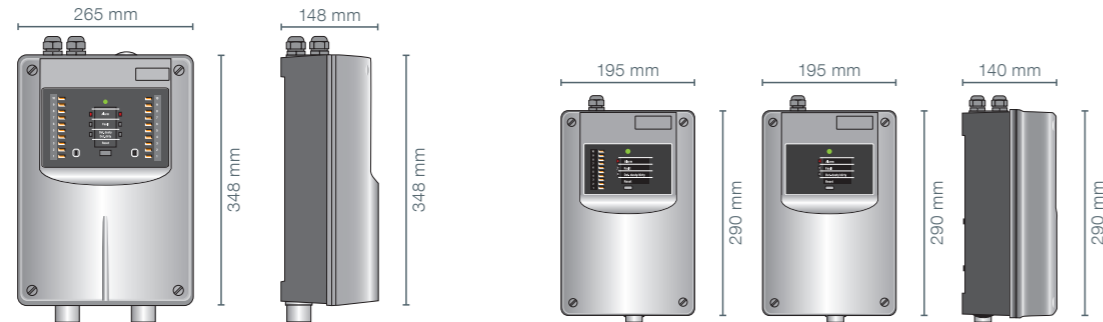

	ASD 535	ASD 533	ASD 532	ASD 531
Product details				
Channels	1/2	1/2	1	1
Smoke sensor	Highly sensitive smoke sensor with high-power LED, LVSC smoke chamber and patented lint filter			
Monitoring area	5760 m ²	3840 m ²	1280 m ²	720 m ²
Smoke level indicator	Series	No	Series	No
Programming (PC tool)	ASD Config	ASD Config	ASD Config	Not available
Configuration	EasyConfig	EasyConfig	EasyConfig	BasiConfig
Sampling pipe calculation	ASD PipeFlow			
Applications	High-bay storage, deep-freeze warehouses, large data centres, historic buildings, large/high halls, etc.	Lift shafts, museums, cultural artefacts, halls, cinemas, etc.	Prison cells, clean rooms, laboratories, server racks, telecommunications facilities, etc.	Individual server racks, clean rooms, false ceilings, etc.
Coated printed circuit boards and surge protection	HD version	—	—	—
Approvals/certificates	VdS, DIBt, UL, FM, ActivFire, CCCF, EAC, SIL	VdS, UL, FM, ActivFire, EAC	VdS, UL, FM, ActivFire, CCCF, EAC, SIL	VdS, UL, FM, ActivFire, CCCF, EAC

		ASD 535	ASD 533	ASD 532	ASD 531
Technical data					
Supply voltage range	EN 54 FM/UL	10.5 to 30 VDC 12.4 to 27 VDC	10.5 to 30 VDC 12.4 to 27 VDC	14.0 to 30 VDC 16.4 to 27 VDC	14.0 to 30 VDC 16.4 to 27 VDC
Power consumption	Type at 24 VDC	260 to 290 mA	130 to 170 mA	115 mA	75 mA
Alarm sensitivity	Alarm Pre-signal	0.02 to 10%/m (0.00087-0.457 dB/m) From 0.002%/m (0.0000869 dB/m)			0.02 to 10%/m From 0.006%/m
Alarm levels		5 (3 pre-signals, alarm, alarm 2) Adjustable pre-signals 10 to 90%			4 (3 pre-signals permanently set 30/50/70%)
Number of sampling holes (with ASD PipeFlow)	EN 54-20, Class A	2 × 18	2 × 16	8	6
	EN 54-20, Class B	2 × 56	2 × 50	12	8
	EN 54-20, Class C	2 × 120	2 × 50	16	12
System limits compliant with EN 54-20, Class C	Max. overall length of all sampling pipes	2 × 300 m	2 × 200 m	120 m	75 m
System limits without standards conformity	Max. overall length of all sampling pipes	2 × 400 m	2 × 200 m	120 m	75 m
Fan/aspirating system	Suction pressure	> 400 Pa	> 170 Pa	> 100 Pa	> 30 Pa
	Sound pressure level	> 34 dB (A)	> 34 dB (A)	> 25 dB (A)	> 25 dB (A)
Housing	Protection type	IP 54 (IP 66: HD version)	IP 54	IP 54	IP 54
Operating temperature/humidity	Evaluation unit	−30 to +60 °C/ 95% RH (UL max. +40 °C)	−20 to +60 °C/ 95% RH (UL max. +40 °C)	−20 to +60 °C/ 95% RH (UL max. +40 °C)	−10 to +55 °C/ 95% RH (UL max. +40 °C)
Relays	Number of 1-channel versions	3 (1 alarm, 1 fault, 1 free)	3 (1 alarm, 1 fault, 1 free)	2 (1 alarm, 1 fault) (use RIM 36 for pre-signals)	
	2-channel version	3 (1 each alarm I and II, 1 fault)	3 (1 each alarm I and II, 1 fault)		
	Contact load	50 VDC / 1 A (UL 30 VDC)			
Interfaces	Open collector outputs	Like relays			
	PC tool	USB	USB	Ethernet	—
	Network	RS 485	RS 485	RS 485, Ethernet	—
	Inputs	Reset, day/night	Reset, day/night	Reset, day/night	Reset
SecuriFire integration		Yes, with XLM-35 module (alarm, pre-signals, faults, day/night sensitivity switching, reset etc.)			
Event memory/analogue values	On board	430 Events	430 Events	1000 events	1000 events



Securiton AG

Alarm and Security Systems
Alpenstrasse 20, CH-3052 Zollikofen
www.securiton.ch, info@securiton.ch

A Swiss Securitas Group company
